

THESE MARKING UNITS ARE MOSTLY RECYCLED FROM PARTS OF THE HARD POPSIS SCREEN.

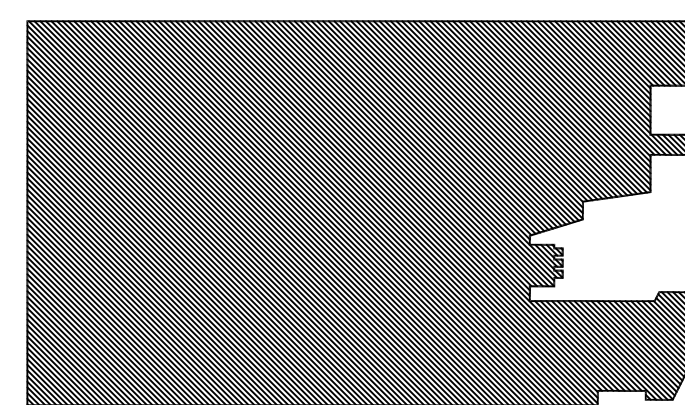
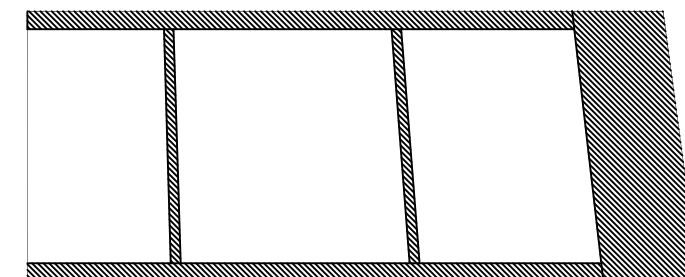
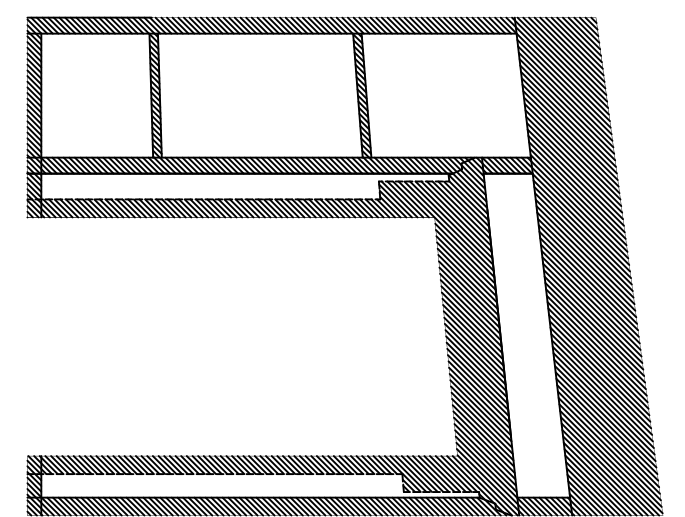
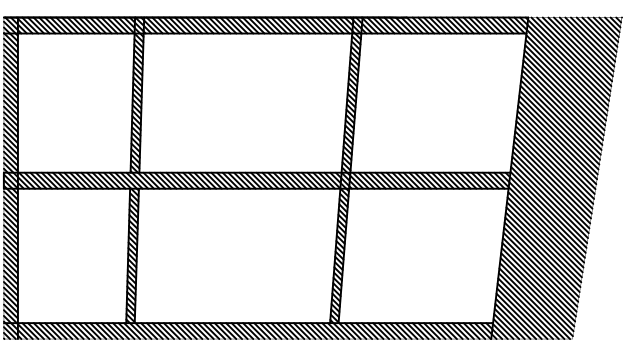
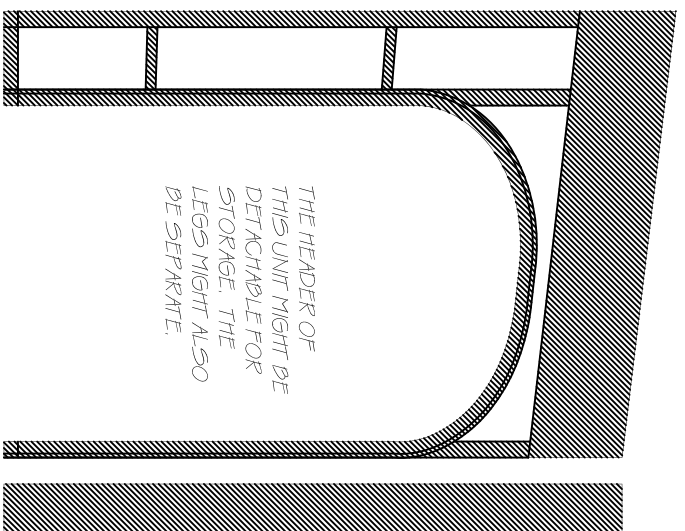
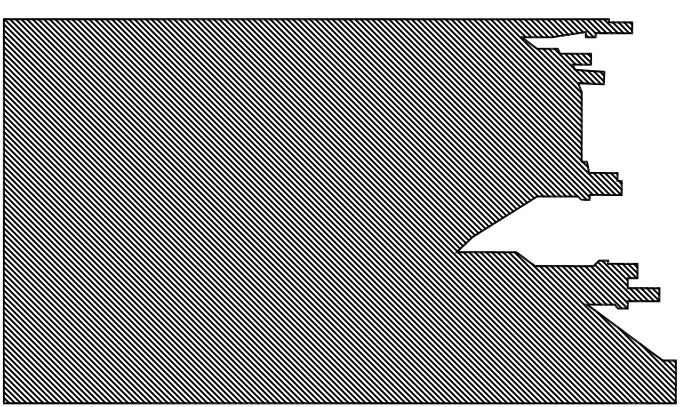
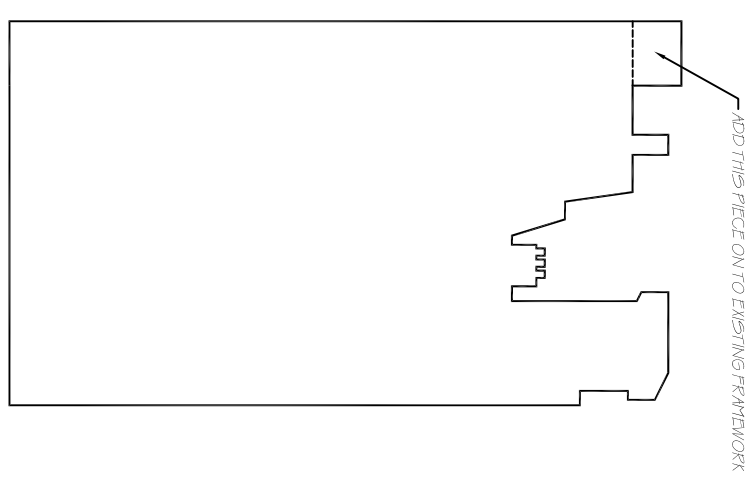
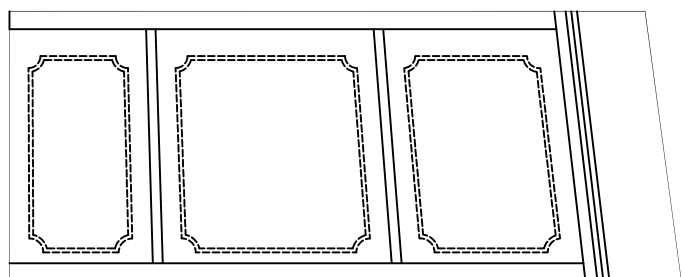
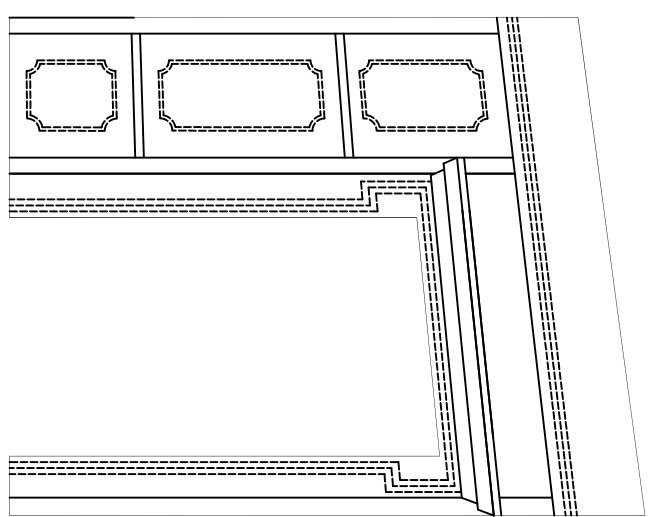
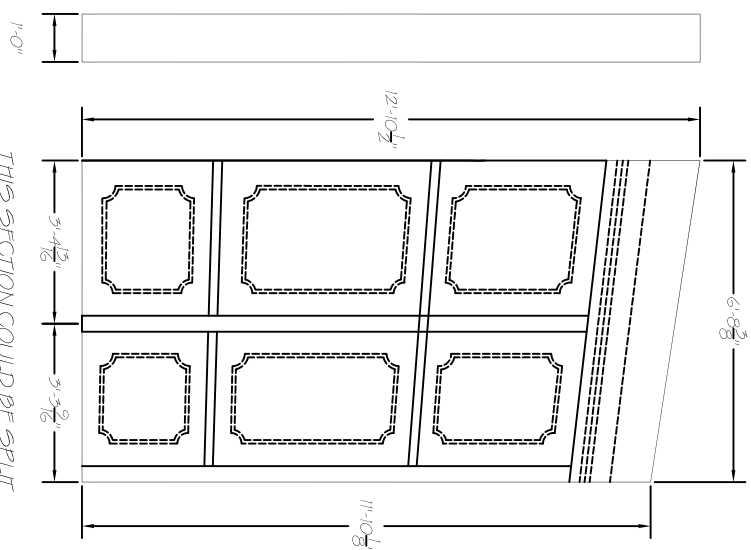
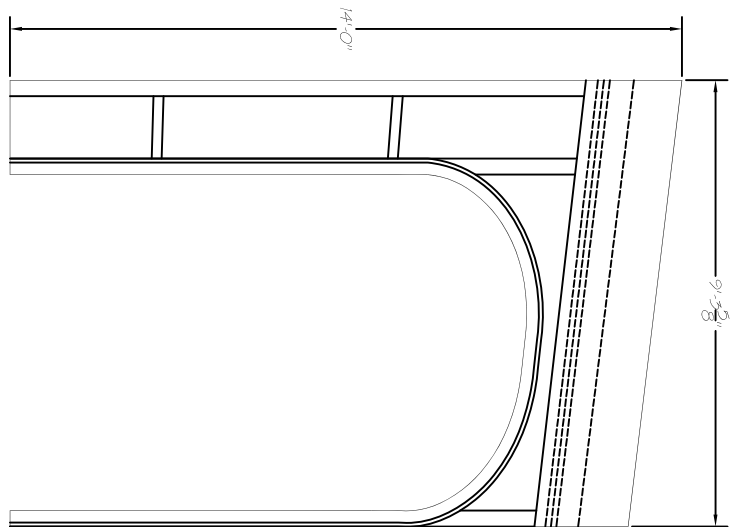

THE SHADED AREAS ARE ANTICIPATED AS BEING OPAQUE. ALL OF THE OTHER AREAS ARE ANTICIPATED AS BEING GRAY SCREEN OR TINTED. THE SHAPED PANELS SHOWN IN THE UPPER ELEVATIONS HERE ARE INTENDED TO BE PAINTED ONLY.

PLATE NO. <b>3</b> OF 7	PLANNING STATE UNIVERSITY <b>A CHRISTMAS CAROL</b> BY PAUL LINDSAY DESIGNED BY PAUL LINDSAY SET DESIGN BY MATT WENZ TECHNICAL DIRECTION AND RENDERING FROM STUDENTS AND FACULTY SCALE: 1/4" = 1'-0"
-------------------------------	--