

THE POSTS CAN BE TIED TOGETHER OR THEY CAN BE ONE SOLID TIE. THEY NEED TO BE MADE THE RED STAINWOOD AND THESE MEASUREMENTS ARE IDENTICAL. CAN YOU HAVE THE SOLID TIE FOR US? THANK YOU!

THESE ARE MEASUREMENTS OF THE POSTS AND NOT THE CASTERS. THE CASTERS ARE NOT SHOWN IN THESE MEASUREMENTS. THE CASTERS ARE NOT SHOWN IN THESE MEASUREMENTS. THE CASTERS ARE NOT SHOWN IN THESE MEASUREMENTS.

PADDED PLATFORM OR MATTERS

USE LARGE SWIVEL CASTERS. SIX-INCH CASTERS ARE SHOWN. ADD A BED SKIRT TO HIDE THEM!

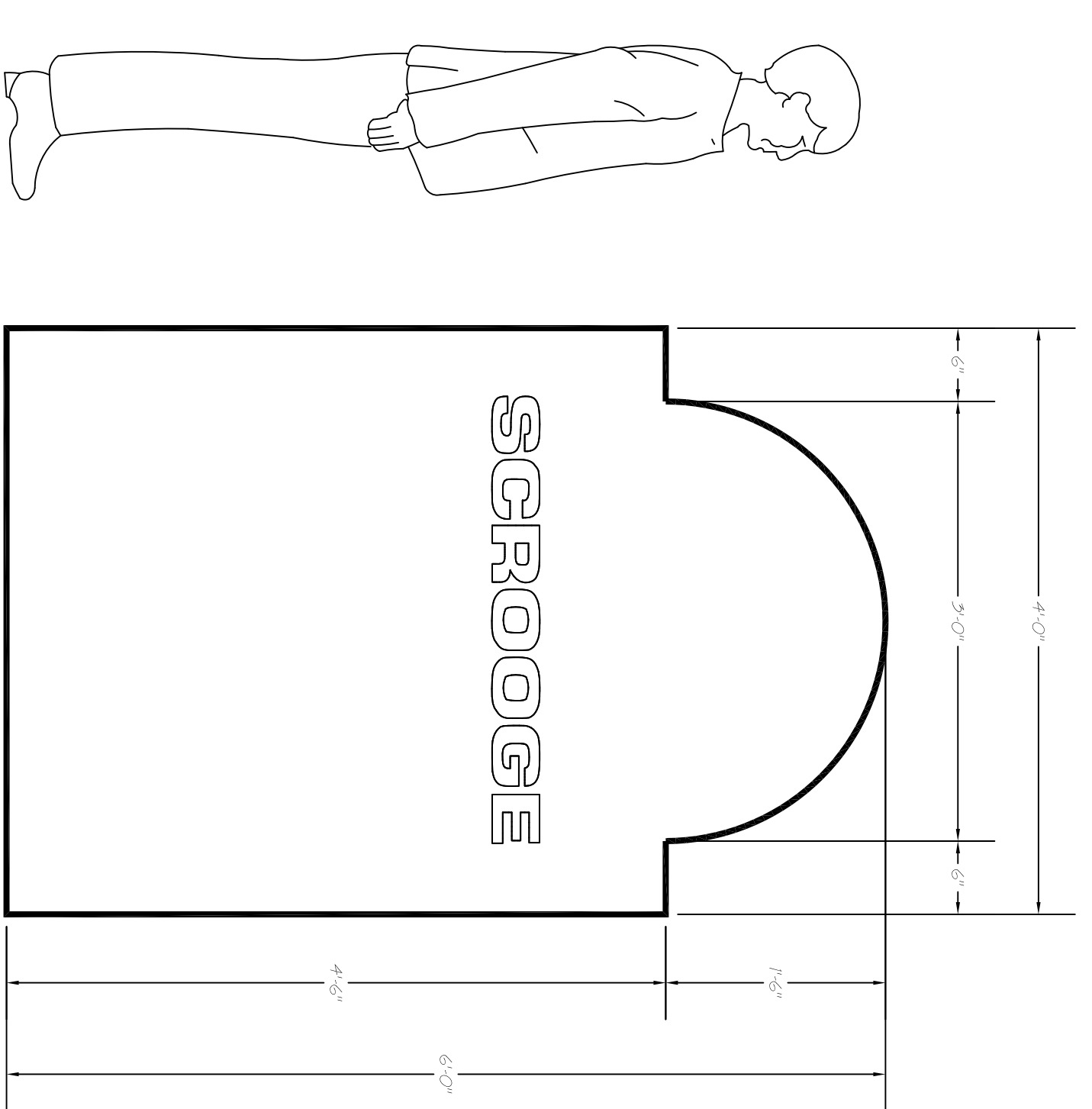

BUILD THE TOMBSTONE ABOUT 12" THICK (OR MORE IF NEEDED). MAKE IT A HOLLOW BOX. PAINT THE INSIDE OF IT FLAT WHITE. PUT A BRIGHT LIGHT SOURCE INSIDE OF IT. CUT OUT THE LETTERS AND BACK THEM WITH WHITE FROST AND RED GEL.

COVER THE FACE WITH REAR-PROJECTION SCREEN. BE SURE THE SCREEN FITS TIGHTLY AGAINST THE LETTERS. THE FACE WILL BE BLANK UNTIL THE LETTERS LIGHT UP. THE SURFACE CAN BE SPONGE-PAINTED AND HAVE MOSS OR VINES APPLIED, JUST AVOID OBSCURING THE LETTERING TOO MUCH.

PLACE A PORTABLE AC POWER INVERTER INSIDE FOR ON ITS BASE, A REMOTE AC SWITCH TURNS IT ON OR OFF, OR A CREW MEMBER CAN HIDE BEHIND IT TO OPERATE A MANUAL SWITCH.

CHI ENTERTAINMENT  
 A CHRISTMAS CAROL  
 DIRECTED BY SCOTT SEVERENCE  
 SET DESIGN BY MATT KIZER

BED & TOMBSTONE  
 SCALE: 1" = 1'-0"

PLATE  
 8  
 OF 10