

CANDLE SITS IN A SLOT ON TOP. IT CAN BE PULLED ACROSS THE TRACK WITH A HIDDEN STRING THAT RUNS THROUGH A SCREW EYE ON SCROOGE'S LEFT.

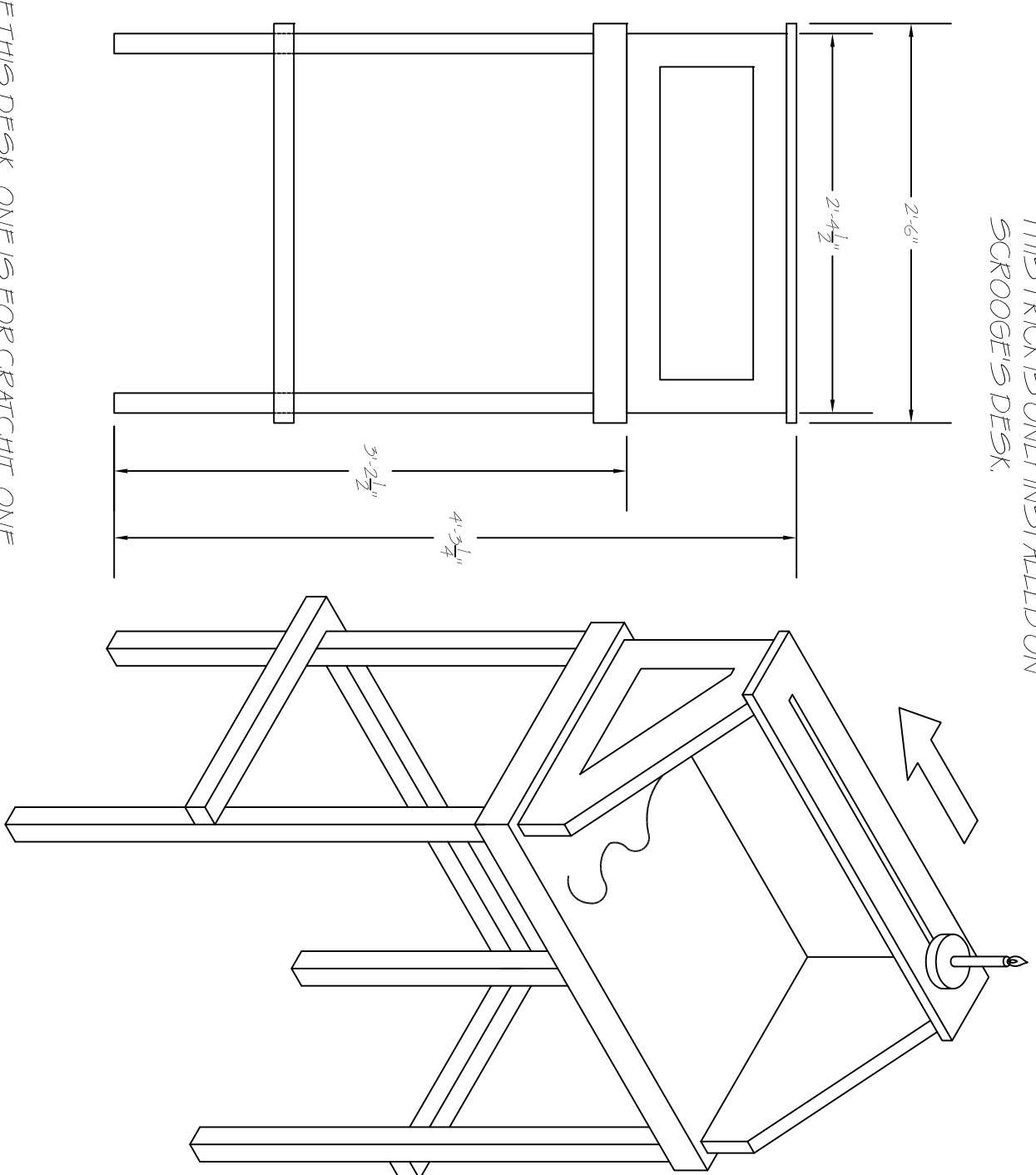

BUILD TWO (2) OF THIS DESK. ONE IS FOR CRATCHIT. ONE IS FOR SCROOGE.
SCROOGE'S DESK IS TALLER AND HAS THE CANDLE TRACK BUILT INTO IT.
CUT ABOUT 2" OFF OF THE HEIGHT OF CRATCHIT'S DESK TO MAKE IT A LITTLE SHORTER.



LAMPPOSTS ARE SOLAR-POWERED FIXTURES MODIFIED TO STAND FREELY. ACTORS CAN TURN THEM ON AND OFF. THEY ARE FREE-STANDING AND SHOULD MOVE EASILY.
SHOWN HERE IS WHAT WAS USED PREVIOUSLY. FOUND ON AMAZON.
Gama Stone Royal Solar Lamp Post and Single Lamp LED Light Fixture, 87 Inch High, Weathered Bronze Finish #G5-985-WB

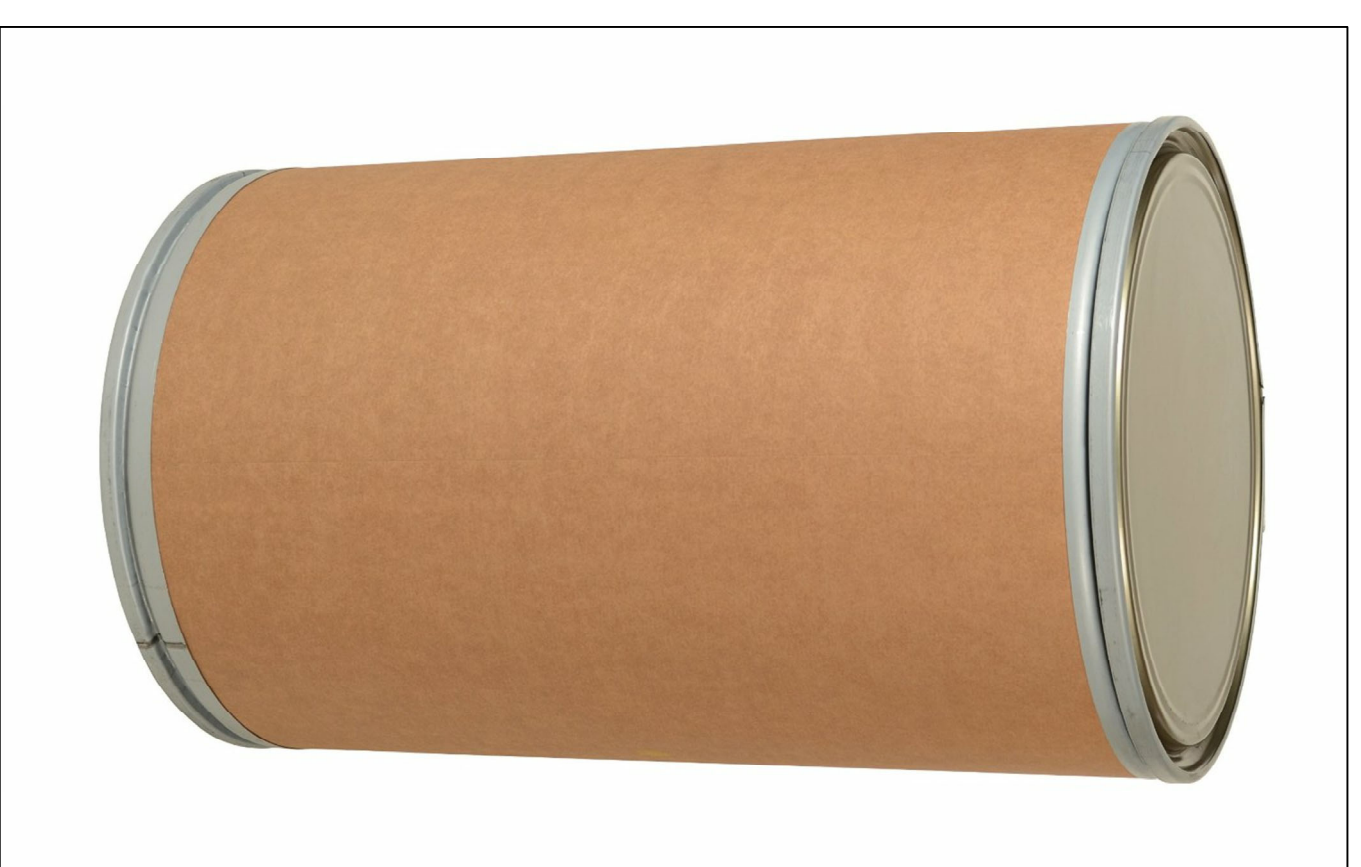

FIBER OPTIC LIGHT
THIS IS 22 1/2" WIDE AND JUST OVER 32" TALL.
AMAZON: Veeall FDP-99 Fiber Optic Head Dim

CHI ENTERTAINMENT
A CHRISTMAS CAROL
DIRECTED BY SCOTT SEVERENCE
SET DESIGN BY MATT KIZER
TECHNICAL DIRECTOR STAN ZABECKI

SET PROPS
SCALE: 1" = 1'-0"