

FLOOR MOUNT THREE ETC. COLOR SOURCE CYCLIGHTS AND FOCUS ON BACKWALL THESE ARE FOR MOMENTS WHEN THE CYCLIS BRIEFLY FLU OUT.

SR BOOM 1

SL BOOM 1

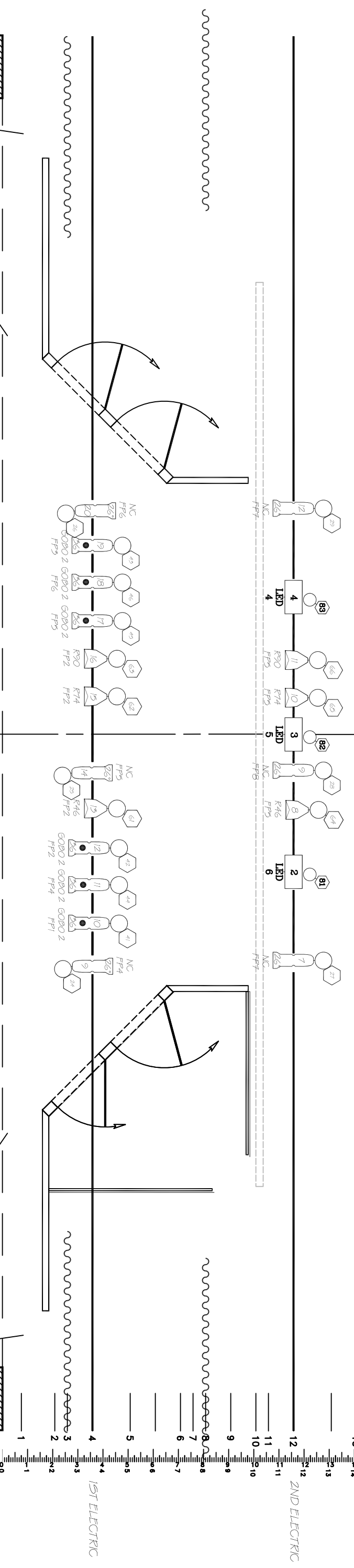

LEGEND

- COLOR FOCUS
- FOCUS AREA
- HIGH END SYSTEMS LONG STRIKE
- LED CYC LIGHT
- S4 PAR WIDE
- S4 PAR MED
- SOURCE 4

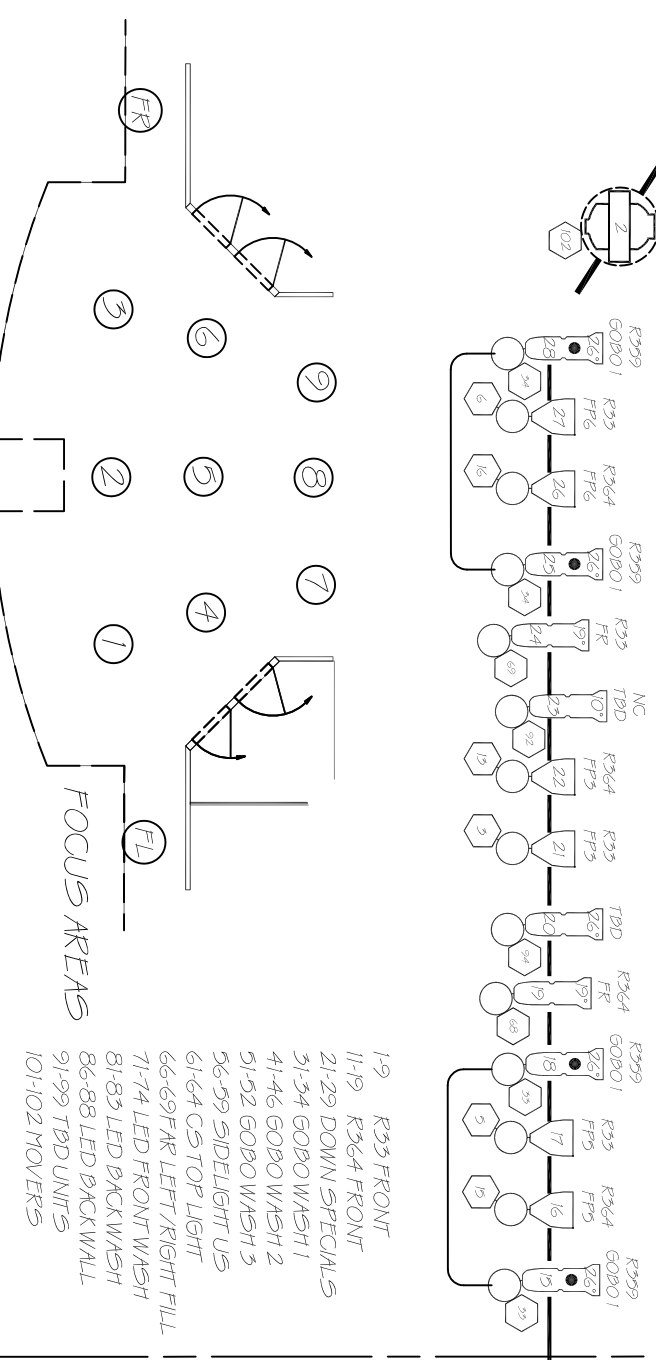

- 1-9 R335 FRONT
- 11-19 R364 FRONT
- 21-29 DOWN SPECIALS
- 31-34 GORO WASH 1
- 41-46 GORO WASH 2
- 51-52 GORO WASH 3
- 56-59 SIDE LIGHT US
- 61-64 C5 TOP LIGHT
- 66-69 FRK LEFT/RIGHT FILL
- 71-74 LED FRONT WASH
- 81-83 LED BACKWASH
- 86-88 LED BACKWALL
- 91-99 TRD UNITS
- 101-102 HOVERS



GOBOS SHOULD BE A BACKUP ABOUT LIKE THIS

PLYMOUTH STATE UNIVERSITY
LUCKY STIFFE
 DIRECTED BY ELIZABETH DAILY
 SET DESIGN BY WATT KIZER
 MASTER ELECTRICIAN: TYLER MCCARTHY
 LIGHTPLOT
 SCALE: AS PRINTED